

KANEKA Thin Film PV
Installation Manual

MODULE TYPE: GSA

KANEKA CORPORATION





3-2-4, NAKANOSHIMA, KITA-KU







OSAKA 530-8288, JAPAN

reference No. GSA211.001

Warning

Meaning of signs

| | | | | | | |
|---|-------------------------------------|---|---|---|--------------------|--|
|  | Not Allowed |  | No Disassembly |  | No Touching | |
|  | Procedures Must be Followed. | |  | Beware of Electric Shock | | |

| | |
|--|--|
| <p>Do not disassemble the PV modules, as this may cause fire, electric shock, and injury.</p> <div style="text-align: right; margin-top: 20px;"></div> | <p>Do not shock the PV module (e.g. by stepping on it), as this may break the glass part and cause malfunction, electric shock and injury.</p> <div style="text-align: right; margin-top: 20px;"></div> |
| <p>Follow the procedure in this manual when installing the PV module and its platform.</p> <div style="text-align: right; margin-top: 20px;"></div> | <p>Beware of electric shock and short-circuit, as the module generates high-tension current when exposed to light.</p> <div style="text-align: right; margin-top: 20px;"></div> |
| <p>Wear a safety belt, protection footwear, and protection gloves when installing the module to prevent falling and electric shock. (Install safety fence and scaffolding to prevent falling.)</p> <div style="text-align: right; margin-top: 20px;"></div> | <p>The platform, connection box, and the inverter (power conditioner) must be grounded based on the regulation about grounding method.</p> <div style="text-align: right; margin-top: 20px;"></div> |
| <p>Do not expose modules to the artificially concentrated sunlight.</p> <div style="text-align: right; margin-top: 20px;"></div> | |

1. Module dimensions

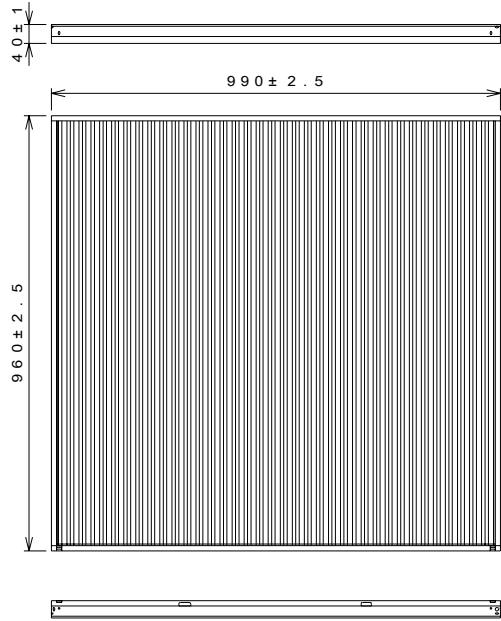

Front View

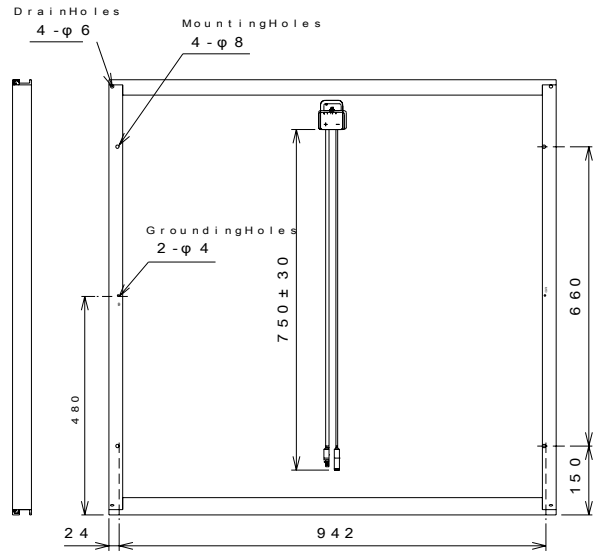

Back View

Weight : 13.7KG / pcs .

| | | | | | | | | |
|-----|------|------|----|-----|--------------|-------|------|------------|
| NO. | REV. | DATE | BY | CHK | DES. & TITLE | SCALE | UNIT | DATE |
| | | | | | 2004.06.11 | 1:10 | mm | |
| | | | | | DESIGNER | | | TITLE |
| | | | | | NAKAJIMA | | | GSA Module |
| | | | | | DESIGNER | | | DS - GSA |

2. Electrical Characteristics of modules

| PRODUCT : THIN-FILM SILICON PV MODULE | | | |
|--|---------------------|------------------------------|------------------------|
| MODEL: GJA211 | DATE: June 01, 2004 | | |
| SPECIFICATION LISTS | UNIT | VALUE | REMARK |
| Performance at STC (stabilized) | | | Tolerance: ±10% |
| Nominal Power (Pmax) | W | 60.0 | |
| Open Circuit Voltage (Voc) | V | 92.0 | |
| Open circuit Voltage (Voc) at -10°C and 1250W/m² | V | 101.2 | |
| Short Circuit Current (Isc) | A | 1.19 | |
| Short Circuit Current (Isc) at 70°C and 1250W/m² | A | 1.53 | |
| Voltage at Pmax (Vpm) | V | 67.0 | |
| Current at Pmax (Ipm) | A | 0.90 | |
| Max. System Voltage | V | 530 | |
| Fire Rating | | Class C | |
| Dimension | mm | 990 ± 2.5 x 960 ± 2.5 | |
| Depth | mm | 40 ± 1.0 | |
| Weight | kg | 13.7 | |

(REMARK)

1. During initial 6 weeks of operation, the MODULE has higher electrical output than rated output (See Performance at STC (stabilized)). The Pmax may be higher by 38% and Imp may be higher by 19%.
2. The Electrical characteristics are within ±10% of the indicated values of Isc, Voc, and Pmax under standard test conditions (irradiance of 100mW/cm², AM1.5 spectrum, and a cell

temperature of 25°C(77°F)).

3. Specifications subject to change without notice.

4. Refer to Section 690-8 of the National Electric Code for an additional multiply factor of 125% (80% derating) which may be applicable.

3.Installation of the modules

Fix the modules to rails with M6 bolts and nuts (4 pairs per module). The platform of modules should have sufficient strength.

The assembly is to be mounted over a fire resistant roof covering rated for the application.

5 in/ft (127mm/305mm) required to maintain a fire Class rating.

Artificially concentrated sunlight shall not be directed on the module.

See the Attachment A: Instruction for using KANEKA PV modules.

(Remark for C-UL)

Installation shall be in accordance with CSA 22.1, Safety Standard for Electrical Installations, Canadian Electrical Code, Part 1.

【Module mounting diagram】

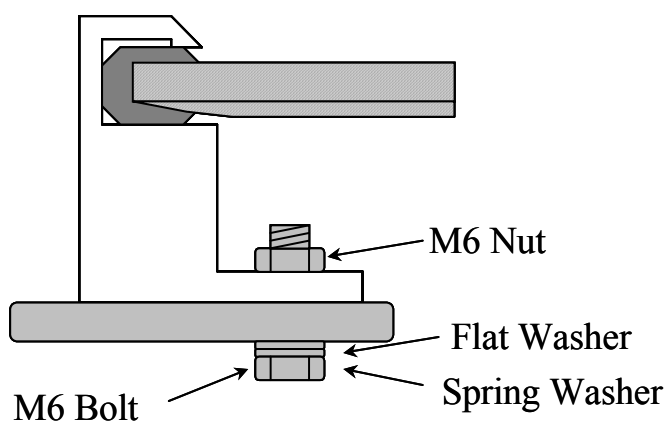

4.Connecting cables

Use 14 AWG minimum cables. Copper only.

When connecting cables, push the plus and minus connectors against each other while twisting them until they are fully engaged.

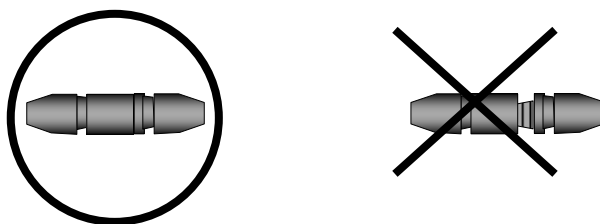

Plus cable connector: PV-KST3II UR (Multi-Contact USA)

Minus cable connector: PV-KBT3II UR (Multi-Contact USA)

Each PV has MC Connector system for photovoltaic, which is supplied from Multi-Contact USA. You should use the same UL recognized connector as written above.

These modules employ factory assembled Multi-Contact connectors for interconnection between modules during array assembly in the field. As these connectors can only be assembled in the factory, we recommend the use of commercially available output wiring products, such as (USE-MCUL-50 made by O&S California, Inc.) so that the final array output wiring can be made to a permanent wiring system in accordance with Article 690-31 of the U.S. National Electrical Code.

More than six (6) modules should not be connected in series. And each string should have a blocking diode or a fuse, which is a 3A of capacity.

See the Attachment A: Instruction for using KANEKA PV modules.

5.Ground-connecting

All the modules should be ground-connected with the ground holes of modules.

Grounding cables must be bolted or screwed with star washers. The grounding cables can be bare or insulated with green colored insulation. The conductor of grounding cables should be sized according to Table 255-122 of the National Electric Code (2002). The bonding paths shall be wired so as not to be broken or disturbed by routine maintenance of modules.

690-5 of the National Electric Code (2002) requires that the PV systems on the residential roofs have ground fault protection equipment. The inverter that have ground fault protection device should be used.

6.Maintenance

Under the normal use maintenance is not necessary. The dirt on the surface of the modules will be washed away by rain.

7.Limitation

See the Attachment A: Instruction for using KANEKA PV modules.